

# isollux™

Intelligent Lighting Solutions

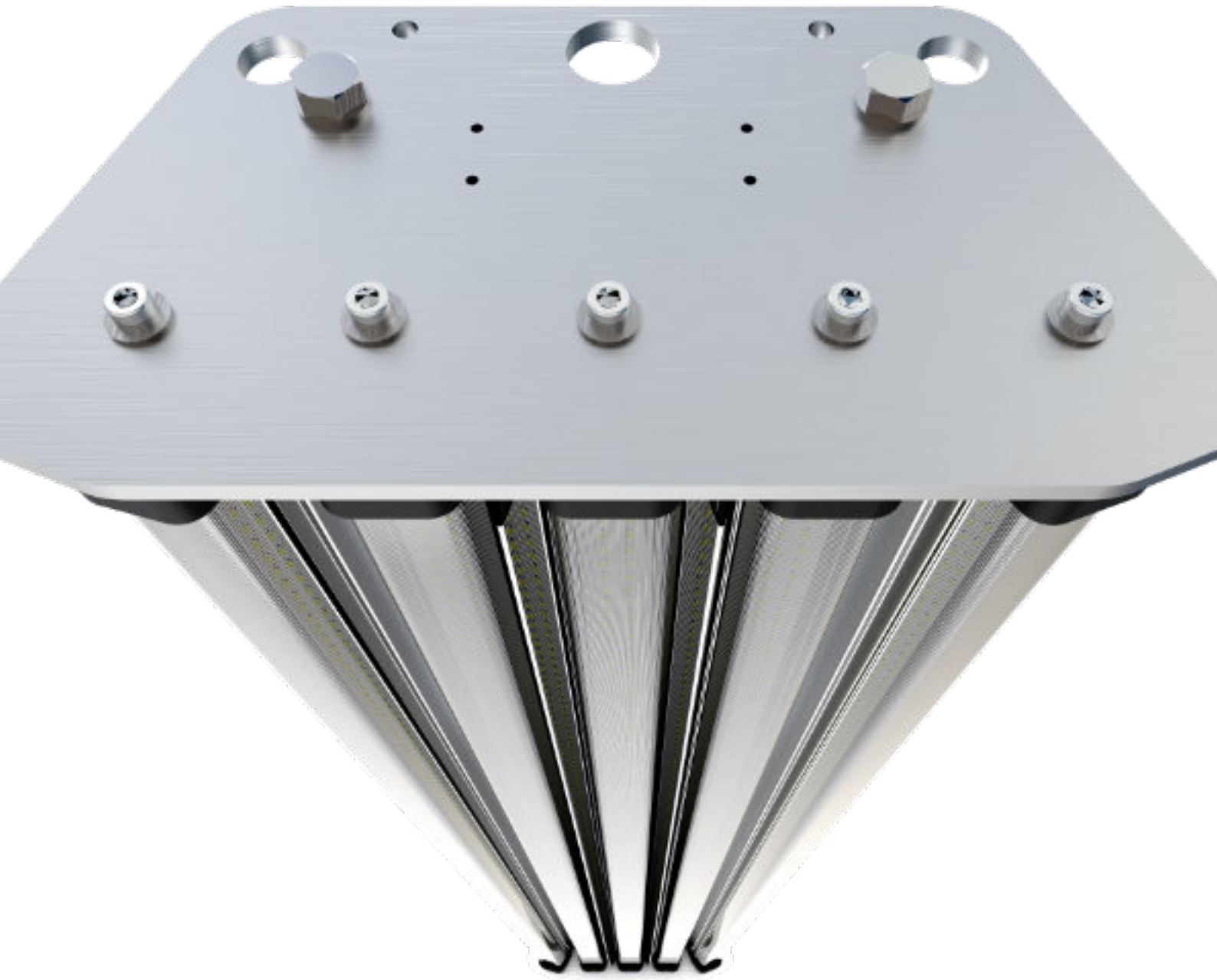

Specifier Series | **ShortBay**



## ShortBay | Specifier Series

ShortBay provides an exceptionally flexible; scalable platform to support architects, specifiers and designers, deliver perfect lighting outcomes across a broad range of design challenges with L90 performance up to 100,000 Hrs\*

---

\* Zero LED failures (subject to ambient temperature and switch cycles)

# Performance Options

With all models IP64 rated, specification starts with selection of the correct light engine by power and ambient temperature range.

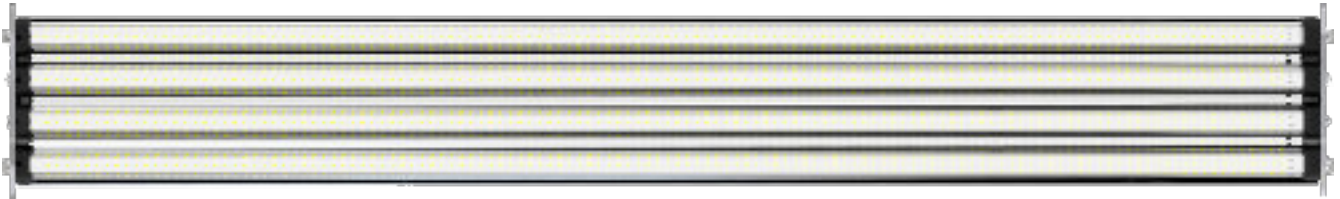

## SB4-HE

180W  
23,040lm\*

Maximum ambient temperature range (-40°C~50°C) suitable for open areas and narrow aisles at heights of up to 10 meters. Typically replaces 400W MH or T5 luminaire.

284 x HE chip per bar (1,136 PCS)

## SB4-HP

180W  
25,200lm\*

Standard ambient temperature range (-40°C~50°C) Suitable for applications up to 12 meters. Typically replaces 450W MH. Features increased chip count for extended service life.

384 x HE chip per bar (1,536 PCS)

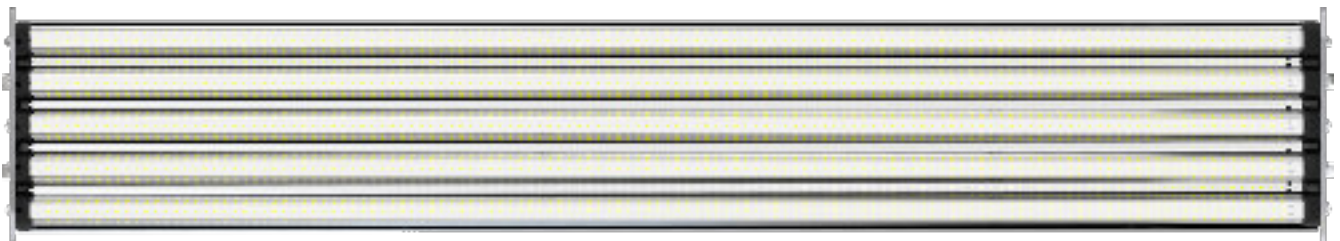

## SB5-HE

220W  
30,800lm\*

Maximum ambient temperature range (-40°C~50°C) suitable for open areas and narrow aisles at heights of up to 14 meters. Provides greater flexibility in tall aisles or where extra power is required to specify Ra95.

284 x HE chip per bar (1,420 PCS)

## SB5-HP

220W  
33,000lm\*

Standard ambient temperature range (-40°C~50°C) Ideal platform to achieve broadcast quality illumination at, Ra95 without compromising lux levels or glare. Increased chip count for longest service life.

384 x HE chip per bar (1,920 PCS)

\* Nominal output (lux) at Ta 25°C, based on CCT 5,000K, Ra85, R9≥10. Ra95 multiplier 0.92



## Adaptive optics

The products feature rotational arrays, with optional reflector packs, that snap between heatsinks. A unique combination that allows for narrow aisle and wide area lighting from a single luminaire. Optics that adjusted on installation to optimise lighting outcomes.

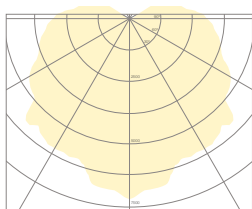
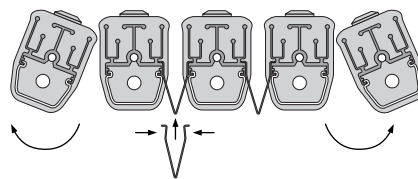

Reflectors to Centre  
Outer Bars Rotated 45°

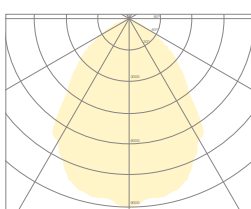

Reflectors to Centre  
Non Rotated

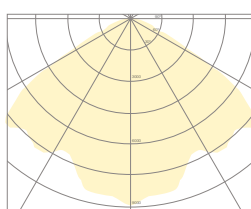

Reflectors to Centre  
Outer Bars Rotated 25°

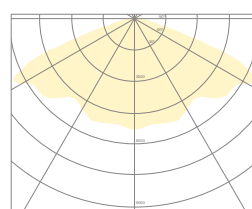

Rotated Arrays  
No Reflectors



## It's true size matters

A light source should not look unnecessarily bright, its function is to light the area around it without causing discomfort. Concentrated, high power light sources viewed against dark backgrounds pose a genuine health risk.

### **Reducing material and component count delivers a low price, but at a cost.**

ShortBay is a large surface emitter, combined with adaptive optics to provide safe uniform light, without glare. Its larger format increases production costs but prevents temporary loss of vision and reduces the risk of associated workplace accidents whilst improving productivity.

Short Bay's large array, higher LED count, primary lens and adaptive optics, deliver a safer work place, devoid of glare. Optimising the transition of power into light.

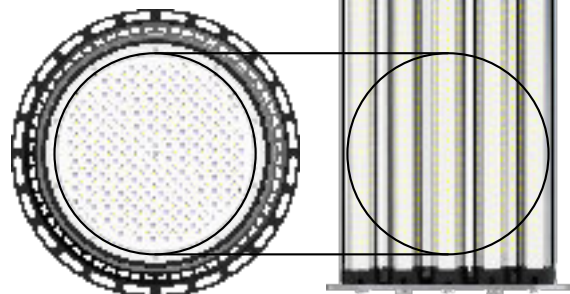



## Unsurpassed uniformity on vertical and horizontal surfaces

ShortBay's adaptive optics, eliminate pooling and shadowing on floors or at the top of high stack warehousing. It delivers unsurpassed levels of uniform on both horizontal and vertical surfaces. Providing the option to modify and refine lighting outcomes during installation, or as the use of your customers facility changes overtime.



The combination of adaptive optics and reflectors delivers exceptionally uniform results even on vertical surfaces.



Many LED high bay present light with significant drop off between fixtures and a dark background.

# Un-compromised colour performance

A productive and healthy working environment requires more than meeting minimum lux levels. Our eyes respond best when presented with a broad spectrum of light, especially during long hours or shift work.

With a minimum colour rendering performance of Ra85, ShortBay is designed to deliver outstanding visual acuity, rich colour, without compromising performance.

## Power to deliver Ra95 in task critical areas.

The product can be specified to Ra95 at no extra cost, to ensure the highest degree of accuracy in task critical areas such as quality control in print production, food processing big box retail and manufacturing.

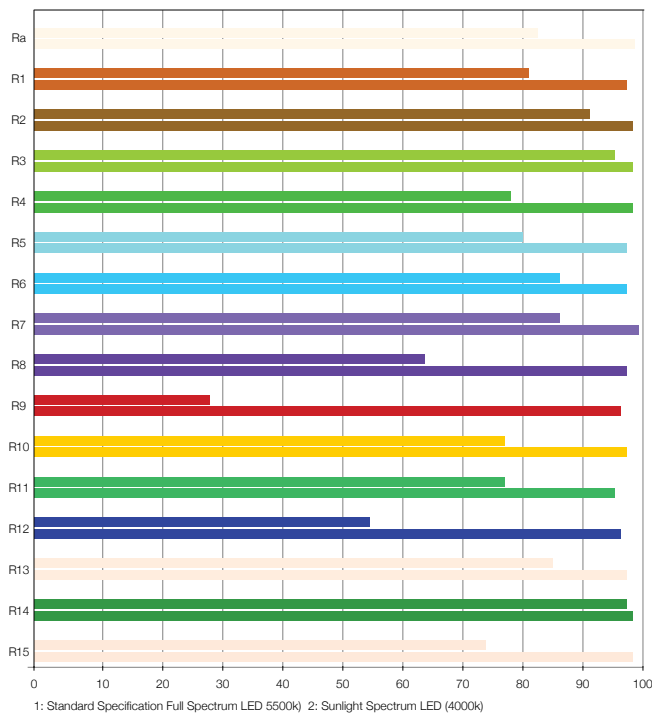



## Built to survive harsh conditions

The ShortBay format adapts to suit the requirements and complexity of the application, from blast freezers to high temperature production areas, with formats and optics designed for blast freezers, food storage and preparation, large format warehousing and manufacturing, smelters and air craft hangers,

Optional chemical protection to PCB and LED arrays and potted IP67 drivers protect sensitive components from exposure to harsh or challenging environments.

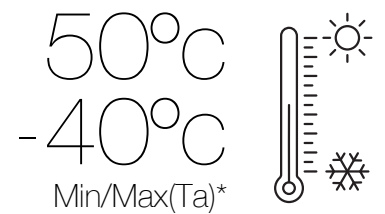

CHEMICAL  
RESISTANCE  
COATING



COOL  
STORE  
SUITABLE



WET  
AREA  
SUITABLE



Up to 100,000 Hrs to L90 and a minimum performance warranty of L70 to five years at maximum ambient temperatures.

With up to 384 individual LEDs per bar operating at just 46% maximum drive current, ShortBay guarantees superb efficiency and maximum service life

Each bar consists of a single PCB, bonded directly to an aluminium heatsink. Optimising transfer of thermal load, with a maintained Tj just 25°C above ambient.

A laser cut and machine folded rigid steel frame provides a the structural base for the full product range, and is the gear tray onto which the power assembly is mounted.

Allowing space between the heatsink and driver plate, eliminates thermal transfer between driver and LED with free air convection to cool components.

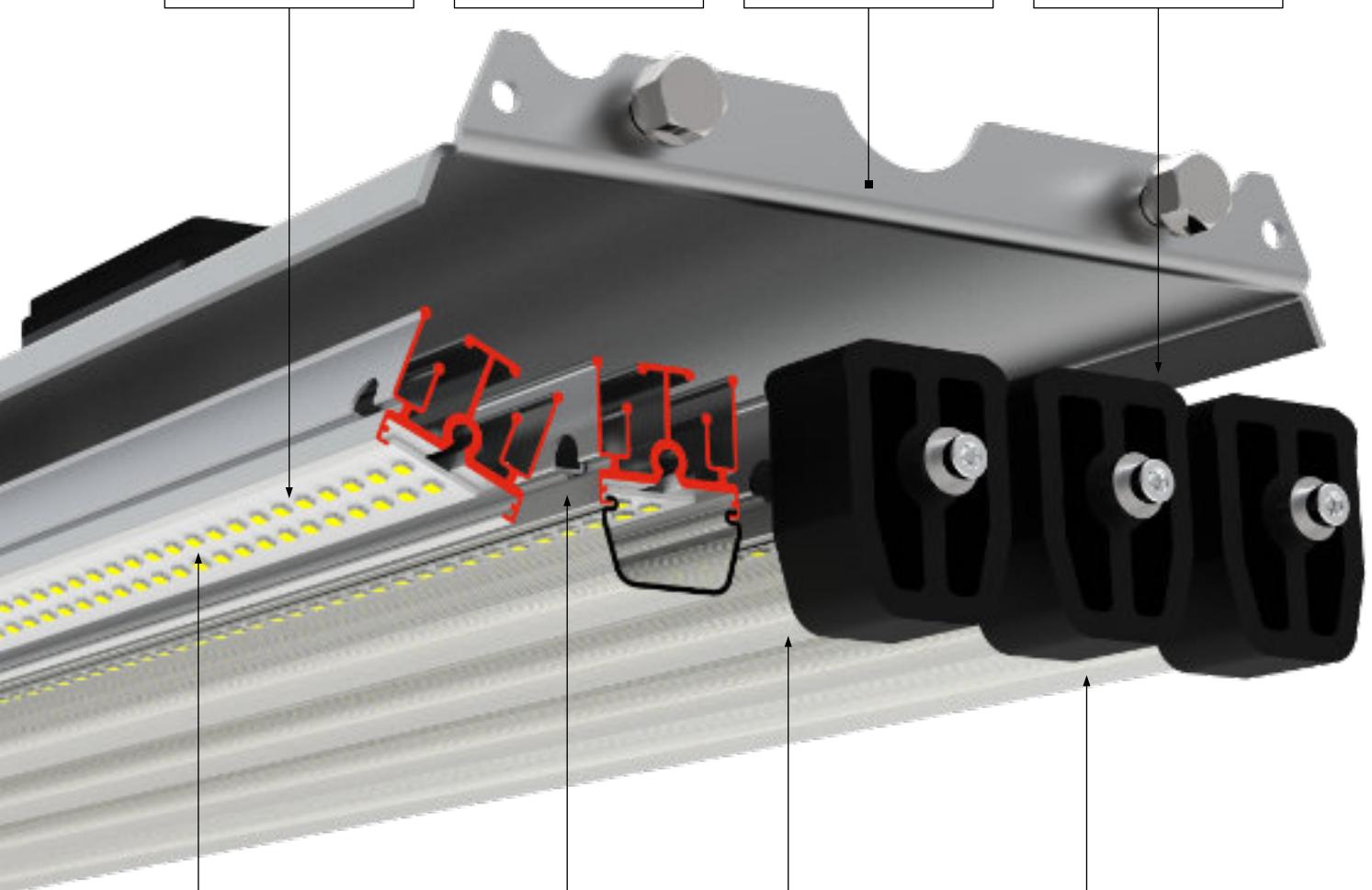

LEDs are sensitive to chemicals such as bromides at just 1.5 PPM. To protect the LED assembly is sealed with a chemical and moisture coating prior to assembly.

A drain hole penetrates the base at each end of the heatsink prevents build up of moisture in areas with dripping water or heavy condensation.

Food safe, lenticular lenses, provide IP64 protection to each light bar, with a smooth outer surface that minimises the build up of dust and grime

Each lite bar terminates at the end plate with a rubber mount to cushion against vibration, fixed to the heatsink by a 304SS M4 machine screw.

Corrosion resistant seismic mounts locking heat sink to gear tray at two positions via 304SS M4.

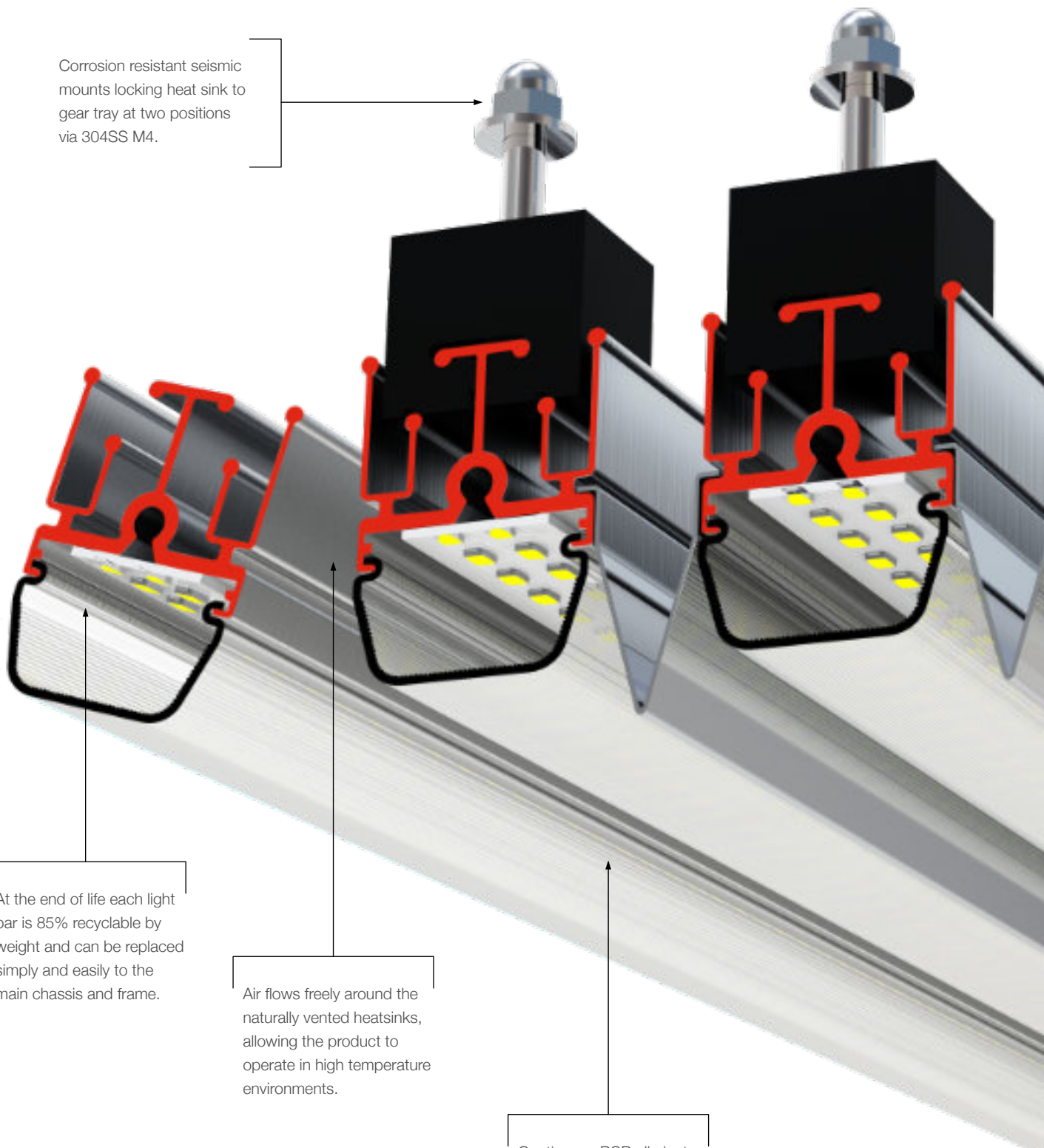

At the end of life each light bar is 85% recyclable by weight and can be replaced simply and easily to the main chassis and frame.

Air flows freely around the naturally vented heatsinks, allowing the product to operate in high temperature environments.

Continuous PCB eliminates common corrosion issues typical of linear LED fixtures improving reliability and endurance.

# Cable Tray and Connection

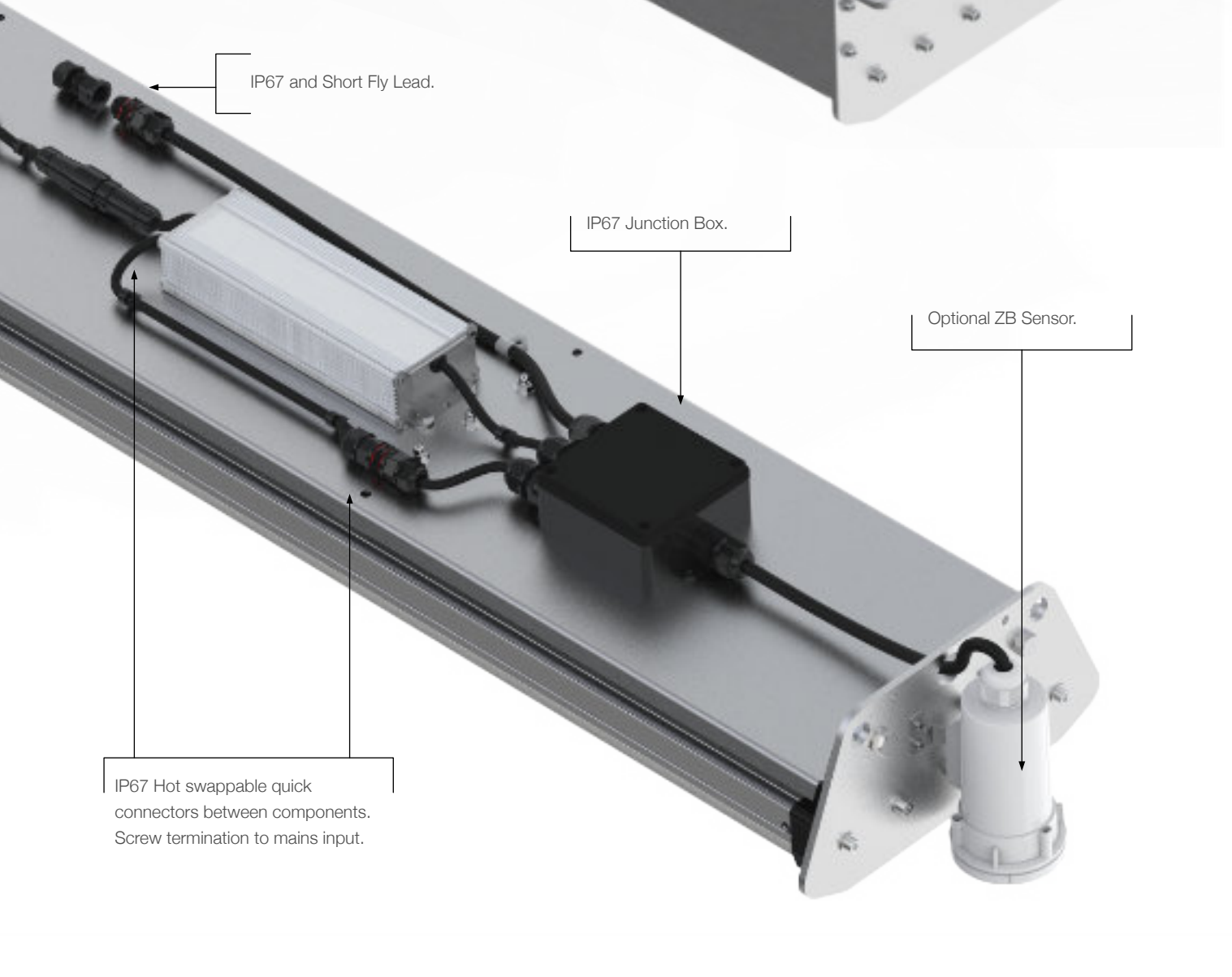
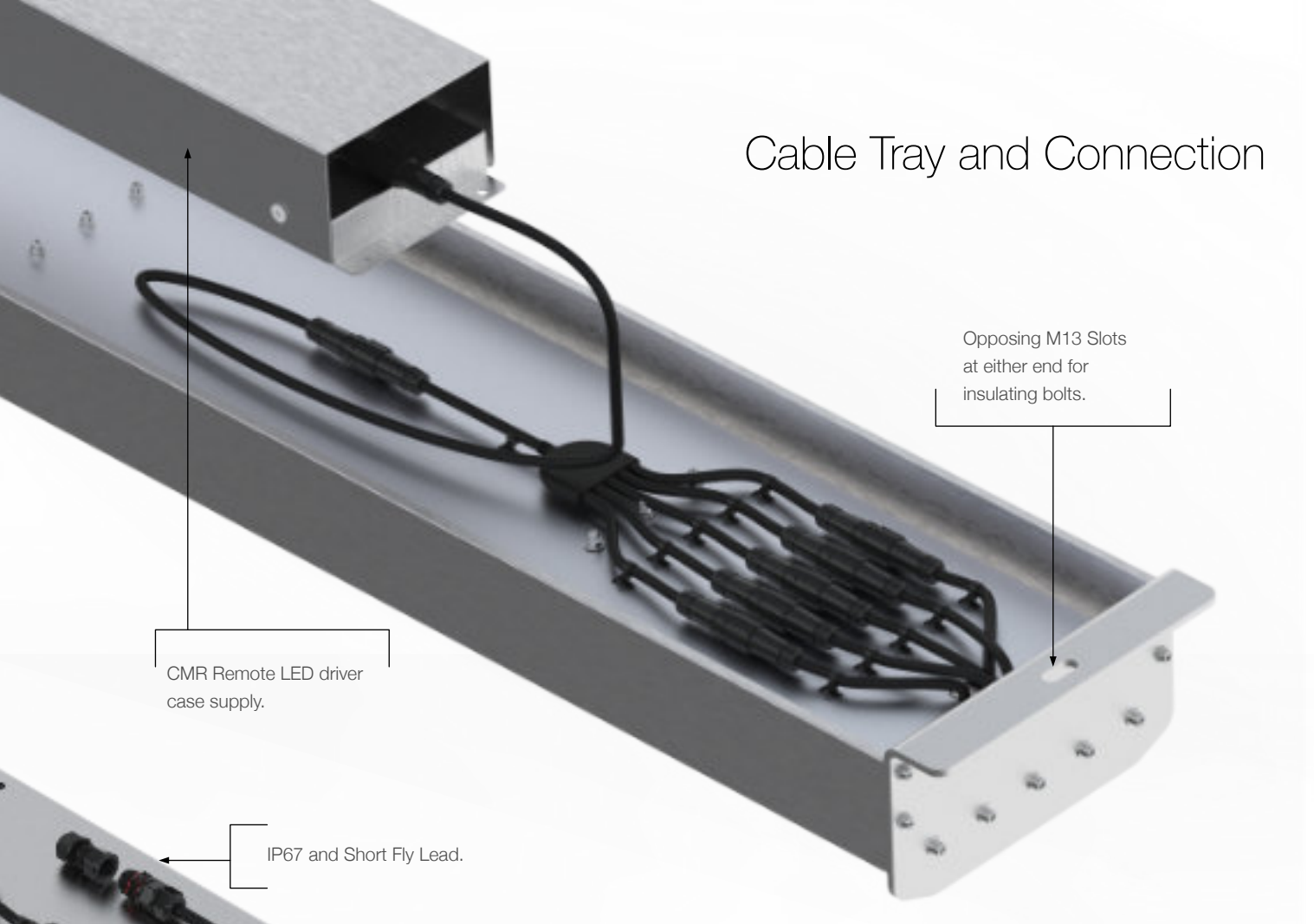

## SB4/SB5 Suspension Mount

The standard SB4 and SB5 are suspension mount high bays with open gear trays and free access to all of the electronic components. Drivers are SELV with a minimum IP65 rating and IP67 rating to all electrical connections on both low and high power circuits.

Dust covers can be added and mount directly to the frame with angles that meet MPI "dust-shed" ratings. Holes at either end provide mounting points for optional IR-TEC ZigBee sensors.

50°C  
-40°C  
Min/Max(Ta)\*

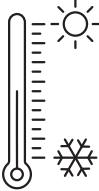
A vertical thermometer icon with a sun symbol at the top and a snowflake symbol at the bottom, indicating a temperature range from 50°C to -40°C.

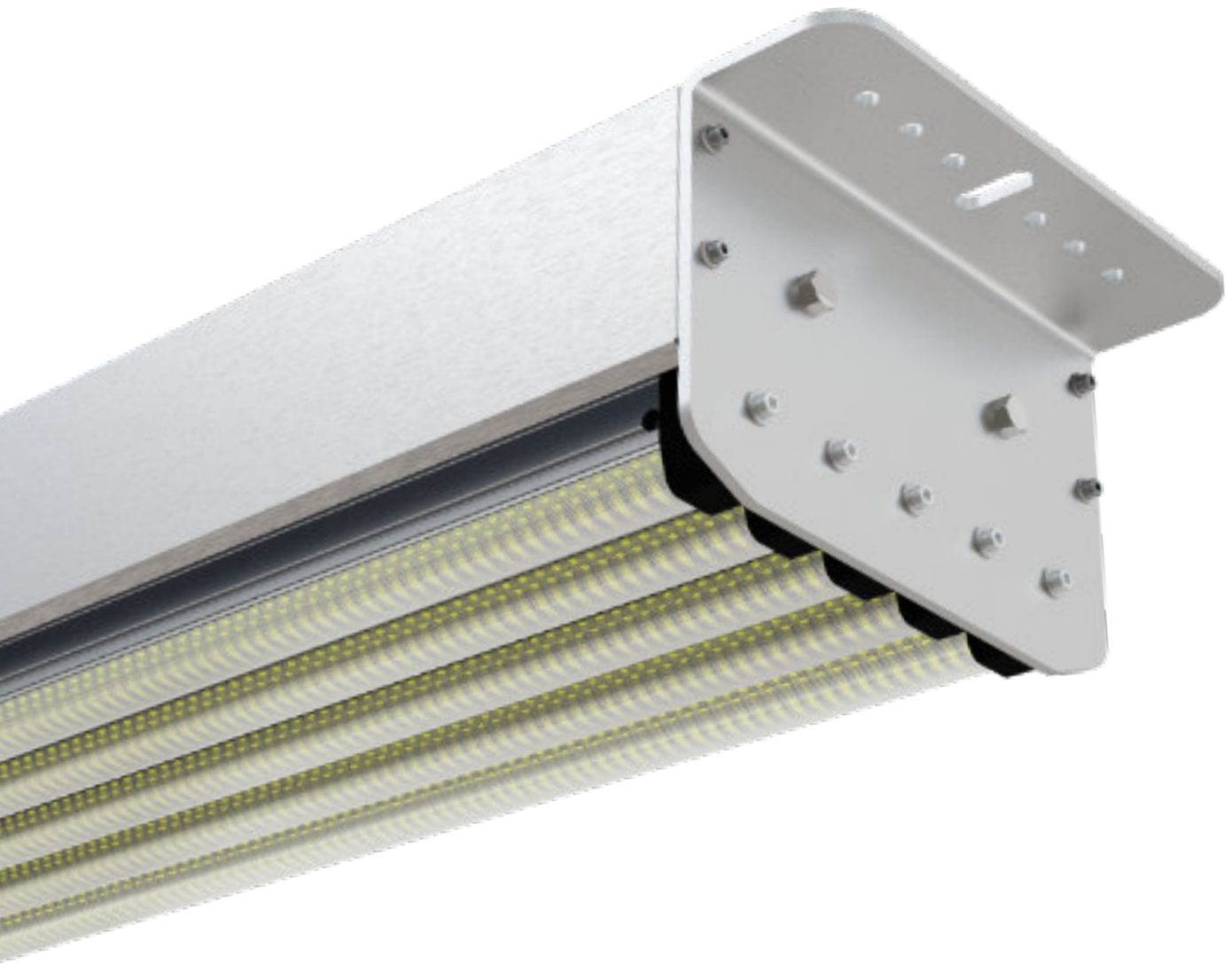

## CMS Surface Mount

The CMS, provides a surface mount solution, ideal for loading bays factories and warehouses where wash downs are not required. It can be directly mounted to roof beam or purlins. the low profile design reduces the risk of accidental damage by fork lifts. The LED driver sits on top of the main tray and is accessible via removable side flashings.

### **Anti-Roosting**

Birds roosting are more than a nuisance. Birds introduce parasites, disease via their droppings and present significant issues in loading bays or storage areas. The CMS side flashings to prevent roosting.

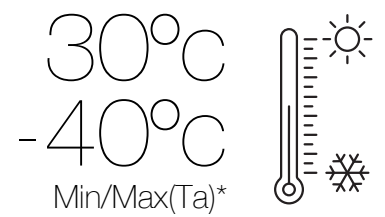

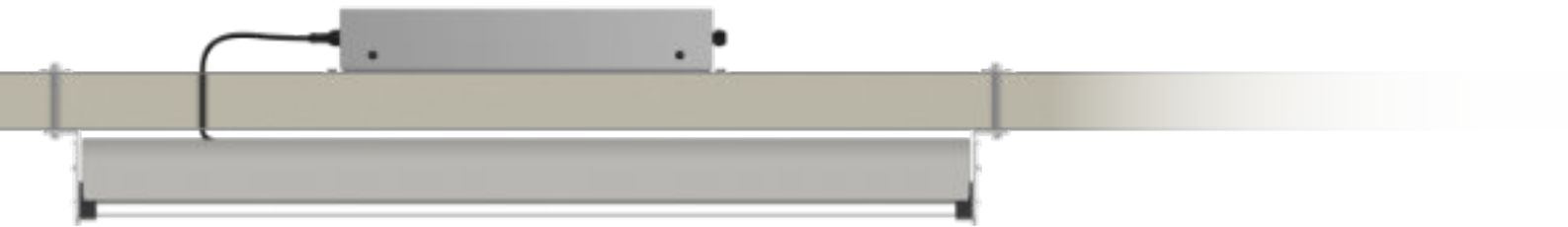



## CMR Blast Freezer Mount

The ShortBay CMR is designed to provide a low profile through ceiling, surface mount solution suitable for insulated panel ceilings common to temperature controlled areas such as blast freezers.

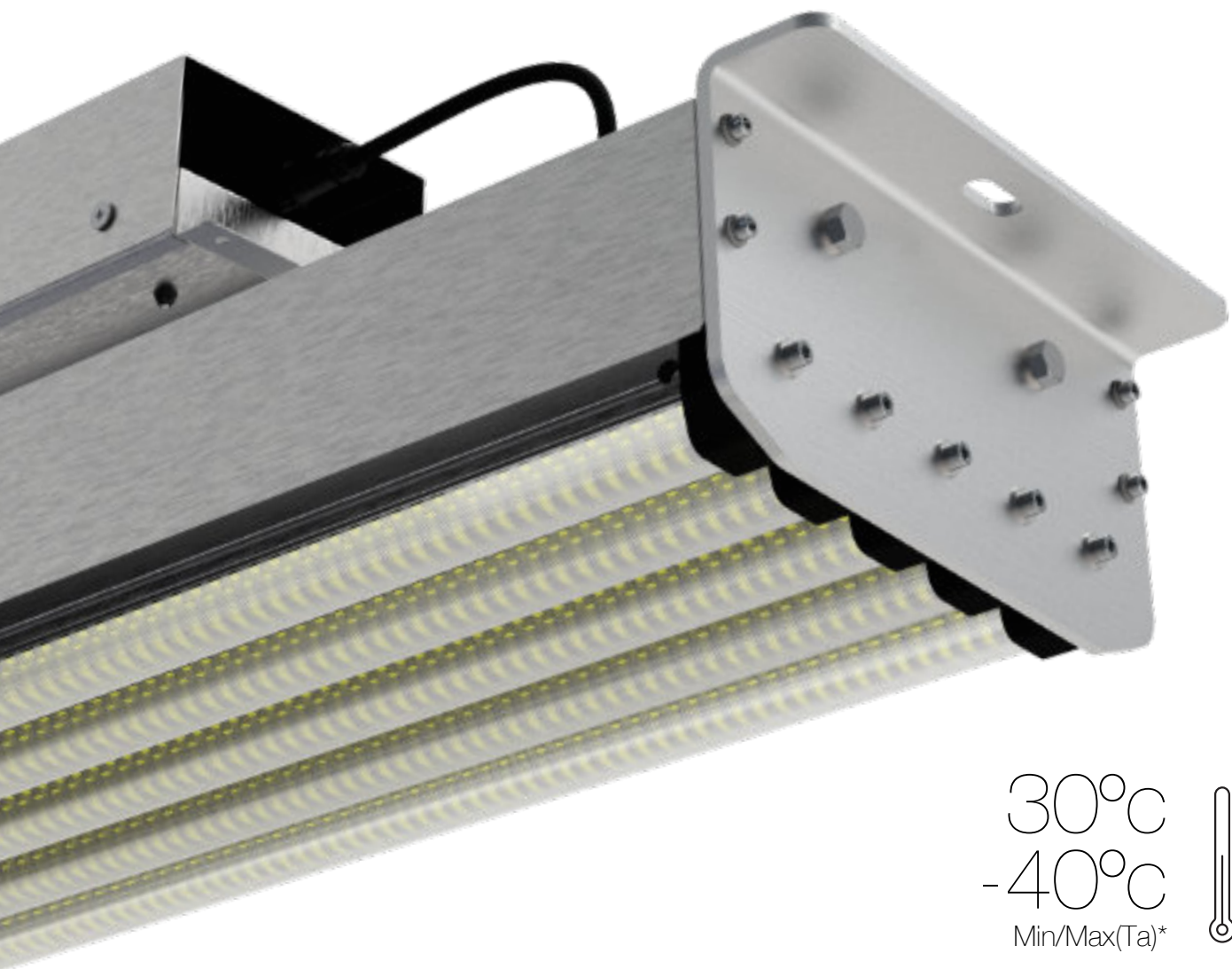
Single point mounts at either end, minimise penetration of the insulated panel and when combined with insulated bolts eliminate thermal transfer through the substrate. The remote driver further minimises thermal load, provides access to the driver for long term maintenance and the ability to combine with emergency packs without damaging batteries.



30°C  
-40°C  
Min/Max(Ta)\*





## CMZ Surface Mount & ZB Sensor

The CMZ extends the functionality of the CMS mount to provide a mount for the optional IP66 ZB sensor from IR-TEC to deliver wireless connected lighting controls, that provide occupancy, and vacancy controls with full daylight harvesting.

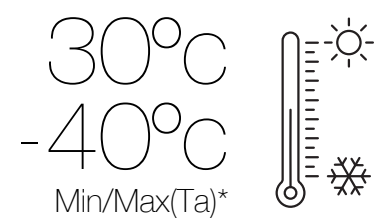



INFRA RED UPLINK

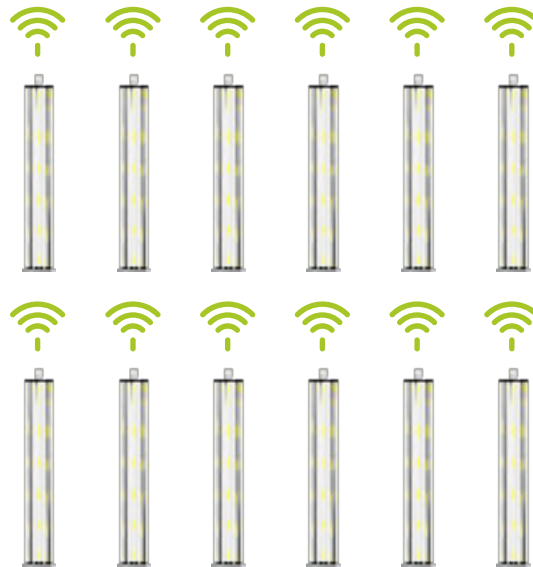

## Reliable mesh network without internet connection

The optional OS-NET ZigBee control system delivers unparalleled control of luminaire without the need for complex programming or data management. Simply program via a point and push infra-red remote.

Select individual lights or program entire groups instantly. Update or change groups at any time, add multiple luminaire to groups or single luminaire to multiple groups.

“Easy Group” settings provide instant access to the most common control needs, but scratch deeper and the system provides intelligent programming that includes: follow me, daylight harvesting, occupancy, vacancy and automatically adjusts to daylight savings.

No ongoing fees, no wireless updates, no complex programming or mapping required. Simple stand alone efficient lighting controls to maximise your energy savings.



OS-NET



# Wireless wall switches provide practical over-ride.

Your facility may only require low lux levels for most of the day with casual traffic, and none when empty. Occasionally however you need maximum power for a short burst of activity.

The OS-NET wireless wall switch provides a simple over-ride command to raise lux levels to max before dimming to off when the area is vacated after a set time.

Easy to install to any mains supply, no direct connection to the luminaire circuit required or batteries to forget. It provides an invaluable link between the luminaire you choose to control, and the operator on the ground.

All programmed from the simple infra-red hand held remote control, light or switch group and ungroup, simple easy and intuitive.

## Multiple lenses and dual sensor control optimise detection.

Behind the lens dual doppler and IR sensors eliminate false detections, whilst a range of hot swappable lenses fine tune the parameters and sensitivity to suit wide or narrow areas and aisles with blanking plates to prevent detection in areas where walkways are close to the wall.

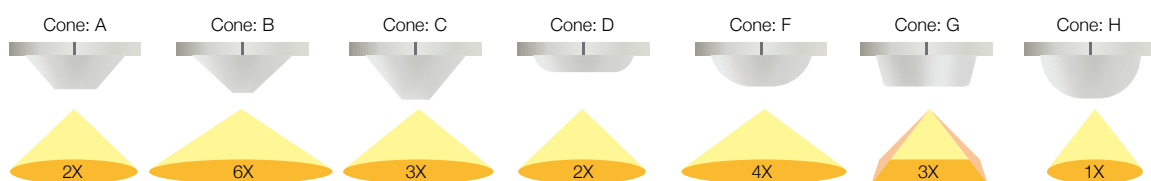

# The sustainable approach

Isollux HE dual chip technology increases LED lifetime up to 200,000 Hrs, with maintenance kits to extend the practical life of the luminaire. Simple, efficient and financially beneficial.

- ▶ Reduces total cost of ownership maximising ROI and NPV
- ▶ Reduces land fill, manufacturing and supply related carbon footprint by up to 640%
- ▶ Delivers a longer practical performance life (L90 >100,000 Hrs\* - L70 > 200,000 Hrs)
- ▶ Supports planned and unscheduled maintenance to the maximum life of the fitting
- ▶ Minimizes downtime with easily maintained and replaceable parts
- ▶ Ensures continuity of fixtures on site
- ▶ Components easily dismantled at end of life for recycling

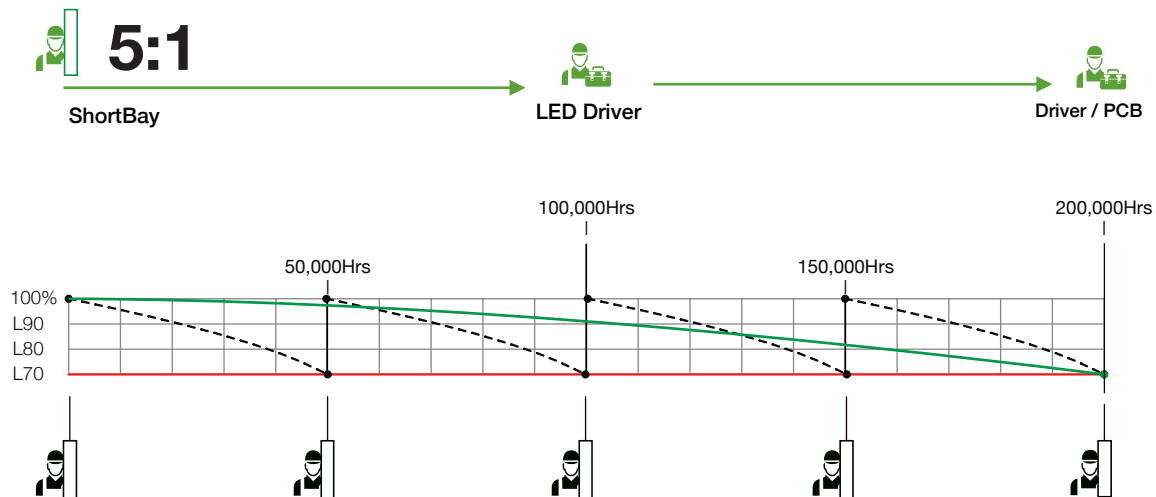

\* HE Chipset L90 Lifetime calculated using 9,000hr independent LM80 photometry report, citing zero failures, using the Energy Star TM-21 protocol. Calculations are based on ambient temperatures of 25°C. Assumes driver replacement as routine maintenance event with driver replacement schedules subject to, power quality, frequency of switching cycles and average to peak ambient operating temperatures. Assumes driver replacement at midpoint of lifecycle, with the calculated MTFB 192.2K hrs min. MIL-HDBK-217F (25°C) based on the 100W 1500mm TPA/TPH. Average driver life 62,000Hrs.



Need more power?

# PowerBay

Whilst ShortBay is sufficiently powerful to deliver excellent lighting outcomes for the majority of commercial applications, when more power is required. PowerBay doubles the format increasing max output to more than 81,000lm @ 5000k, Ra85/ R9≥15 (76,000lm @ Ra95) for a truly breathtaking display of glare free, large format lighting.

The system is capable of bathing vast areas such as air craft hangers and sports stadiums with video safe, flicker free light with options suitable for broadcast applications. The PowerBay series is designed for each application and can be customised with a range of additional mounts and structural formats to meet any design challenge.

## PB6

220W - 270W

28,160LM 40,500LM



## PB8

300W - 360W

38,400LM 54,000LM



## PB10

400W - 450W

51,200LM 67,500LM



## PB12

480W - 540W

61,440LM 81,000LM



# Standard Suspension Mount / Open Gear Tray

PRODUCT	PERFORMANCE			AMBIENT		DRIVER	INRUSH	MAX PSU	WARRANTY
Model Number *	Output	Power	Efficiency	Min	Max°	Function	Amps	Type C Breaker	24/7 @ max (Ta)
<b>4 Lite Bar</b>									
SB4-HE-YYY-180W-ND -(R)	25,200lm	180W	140lm/W	-40°C	50°C	Non Dim	65A	7 @ 230 Vac	5 YRS
SB4-HE-YYY-180W-DM -(R)	25,200lm	180W	140lm/W	-40°C	50°C	0-10V	65A	7 @ 230 Vac	5 YRS
SB4-HE-YYY-180W-ZB -(R)	25,200lm	180W	140lm/W	-40°C	50°C	0-10V	65A	7 @ 230 Vac	5 YRS
SB4-HE-YYY-180W-DA -(R)	25,200lm	180W	140lm/W	-40°C	50°C	DALI	60A	6 @ 230 Vac	5 YRS
<b>4 Lite Bar</b>									
SB4-HP-YYY-180W-ND -(R)	27,000lm	180W	150lm/W	-40°C	50°C	Non Dim	65A	7 @ 230 Vac	7 YRS
SB4-HP-YYY-180W-DM -(R)	27,000lm	180W	150lm/W	-40°C	50°C	0-10V	65A	7 @ 230 Vac	7 YRS
SB4-HP-YYY-180W-ZB -(R)	27,000lm	180W	150lm/W	-40°C	50°C	0-10V	65A	7 @ 230 Vac	7 YRS
SB4-HP-YYY-180W-DA -(R)	27,000lm	180W	150lm/W	-40°C	50°C	DALI	60A	6 @ 230 Vac	5 YRS
<b>5 Lite Bar</b>									
SB5-HE-YYY-220W-ND -(R)	30,800lm	220W	140lm/W	-40°C	50°C	Non Dim	65A	4 @ 230 Vac	5 YRS
SB5-HE-YYY-220W-DM -(R)	30,800lm	220W	140lm/W	-40°C	50°C	0-10V	65A	4 @ 230 Vac	5 YRS
SB5-HE-YYY-220W-ZB -(R)	30,800lm	220W	140lm/W	-40°C	50°C	0-10V	65A	4 @ 230 Vac	5 YRS
SB5-HE-YYY-220W-DA -(R)	30,800lm	220W	140lm/W	-40°C	50°C	DALI	60A	6 @ 230 Vac	5 YRS
<b>5 Lite Bar</b>									
SB5-HP-YYY-220W-ND -(R)	33,000lm	220W	150lm/W	-40°C	50°C	Non Dim	65A	4 @ 230 Vac	7 YRS
SB5-HP-YYY-220W-DM -(R)	33,000lm	220W	150lm/W	-40°C	50°C	0-10V	65A	4 @ 230 Vac	7 YRS
SB5-HP-YYY-220W-ZB -(R)	33,000lm	220W	150lm/W	-40°C	50°C	0-10V	65A	4 @ 230 Vac	7 YRS
SB5-HP-YYY-220W-DA -(R)	33,000lm	220W	150lm/W	-40°C	50°C	DALI	60A	6 @ 230 Vac	5 YRS

**(X)** Correlated Colour Temperature options include: 4000°K **(4)** | 5000°K **(5)** | 6000°K **(6)**

**(YY)** Ra (CRI) Options include Ra85 **(85)**, Ra95. **(95)** Example: 5,000k Ra85, YYY = 585

- **(R)** When reflectors\* are required add -R, to end of standard code, blank when not required.

**ND** Non dimming (Vo to reduce output)

**DM** 1-10V Dimming

**ZB** 1-10V Dimming (Excludes sensor)\*

**DA** DALI

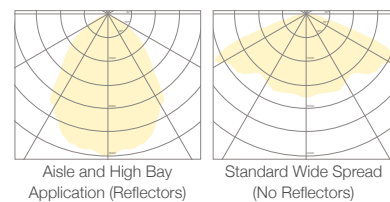

\*High radiant temperatures or unexpected heat sources can potentially damage or significantly impair the performance of the luminaire. Please contact Isollux prior to installation if further information is required.

# Surface Mount with Through Ceiling Remote Driver Box

PRODUCT	PERFORMANCE			AMBIENT		DRIVER	INRUSH	MAX PSU	WARRANTY
Model Number *	Output	Power	Efficiency	Min	Max°	Function	Amps	Type C Breaker	24/7 @ max (Ta)
<b>4 Lite Bar</b>									
CMR4-HE-XYX-180W-ND -(R)	25,200lm	180W	140lm/W	-40°C	30°C	Non Dim	65A	7 @ 230 Vac	5 YRS
CMR4-HE-XYX-180W-DM -(R)	25,200lm	180W	140lm/W	-40°C	30°C	0-10V	65A	7 @ 230 Vac	5 YRS
CMR4-HE-XYX-180W-DA -(R)	25,200lm	180W	140lm/W	-40°C	30°C	DALI	60A	6 @ 230 Vac	5 YRS
<b>4 Lite Bar</b>									
CMR4-HP-XYX-180W-ND -(R)	27,000lm	180W	150lm/W	-40°C	30°C	Non Dim	65A	7 @ 230 Vac	7 YRS
CMR4-HP-XYX-180W-DM -(R)	27,000lm	180W	150lm/W	-40°C	30°C	0-10V	65A	7 @ 230 Vac	7 YRS
CMR4-HP-XYX-180W-DA -(R)	27,000lm	180W	150lm/W	-40°C	30°C	DALI	60A	6 @ 230 Vac	5 YRS
<b>5 Lite Bar</b>									
CMR5-HE-XYX-220W-ND -(R)	30,800lm	220W	140lm/W	-40°C	30°C	Non Dim	65A	4 @ 230 Vac	5 YRS
CMR5-HE-XYX-220W-DM -(R)	30,800lm	220W	140lm/W	-40°C	30°C	0-10V	65A	4 @ 230 Vac	5 YRS
CMR5-HE-XYX-220W-DA -(R)	30,800lm	220W	140lm/W	-40°C	30°C	DALI	60A	6 @ 230 Vac	5 YRS
<b>5 Lite Bar</b>									
CMR5-HP-XYX-220W-ND -(R)	33,000lm	220W	150lm/W	-40°C	30°C	Non Dim	65A	4 @ 230 Vac	7 YRS
CMR5-HP-XYX-220W-DM -(R)	33,000lm	220W	150lm/W	-40°C	30°C	0-10V	65A	4 @ 230 Vac	7 YRS
CMR5-HP-XYX-220W-DA -(R)	33,000lm	220W	150lm/W	-40°C	30°C	DALI	60A	6 @ 230 Vac	5 YRS

- (X)** Correlated Colour Temperature options include: 4000°K **(4)** | 5000°K **(5)** | 6000°K **(6)**
- (YY)** Ra (CRI) Options include Ra85 **(85)**, Ra95. **(95)** Example: 5,000k Ra85, XYX = 585
- (R)** When reflectors\* are required add -R, to end of standard code, blank when not required.
- ND** Non dimming (Vo to reduce output)
- DM** 1-10V Dimming
- DA** DALI

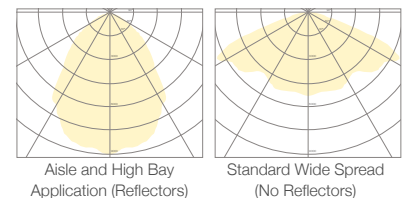

\*High radiant temperatures or unexpected heat sources can potentially damage or significantly impair the performance of the luminaire. Please contact Isollux prior to installation if further information is required.

# Surface / Purlin Mount with Side Flashing and Internal Driver

PRODUCT	PERFORMANCE			AMBIENT		DRIVER	INRUSH	MAX PSU	WARRANTY
Model Number *	Output	Power	Efficiency	Min	Max°	Function	Amps	Type C Breaker	24/7 @ max (Ta)
<b>4 Lite Bar</b>									
CMS4-HE-XXX-180W-ND -(R)	25,200lm	180W	140lm/W	-40°C	30°C	Non Dim	65A	7 @ 230 Vac	5 YRS
CMS4-HE-XXX-180W-DM -(R)	25,200lm	180W	140lm/W	-40°C	30°C	0-10V	65A	7 @ 230 Vac	5 YRS
CMS4-HE-XXX-180W-DA -(R)	25,200lm	180W	140lm/W	-40°C	30°C	DALI	60A	6 @ 230 Vac	5 YRS
<b>5 Lite Bar</b>									
CMS5-HE-XXX-220W-ND -(R)	30,800lm	220W	140lm/W	-40°C	30°C	Non Dim	65A	4 @ 230 Vac	5 YRS
CMS5-HE-XXX-220W-DM -(R)	30,800lm	220W	140lm/W	-40°C	30°C	0-10V	65A	4 @ 230 Vac	5 YRS
CMS5-HE-XXX-220W-DA -(R)	30,800lm	220W	140lm/W	-40°C	30°C	DALI	60A	6 @ 230 Vac	5 YRS
CMS5-HP-XXX-220W-ND -(R)	33,000lm	220W	150lm/W	-40°C	30°C	Non Dim	65A	4 @ 230 Vac	7 YRS
CMS5-HP-XXX-220W-DM -(R)	33,000lm	220W	150lm/W	-40°C	30°C	0-10V	65A	4 @ 230 Vac	7 YRS
CMS5-HP-XXX-220W-DA -(R)	33,000lm	220W	150lm/W	-40°C	30°C	DALI	60A	6 @ 230 Vac	5 YRS

**(X)** Correlated Colour Temperature options include: 4000°K **(4)** | 5000°K **(5)** | 6000°K **(6)**  
**(YY)** Ra (CRI) Options include Ra85 **(85)**, Ra95. **(95)** Example: 5,000k Ra85, XXX = 585  
 - **(R)** When reflectors\* are required add -R, to end of standard code, blank when not required.

**ND** Non dimming (Vo to reduce output)

**DM** 1-10V Dimming

**DA** DALI

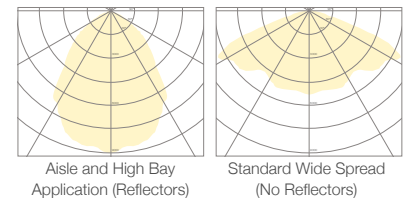

\*High radiant temperatures or unexpected heat sources can potentially damage or significantly impair the performance of the luminaire. Please contact Isollux prior to installation if further information is required.

# Surface / Purlin Mount with Extended Bracket for ZB Sensor / Internal Driver

PRODUCT	PERFORMANCE			AMBIENT		DRIVER	INRUSH	MAX PSU	WARRANTY
Model Number *	Output	Power	Efficiency	Min	Max°	Function	Amps	Type C Breaker	24/7 @ max (Ta)
<b>4 Lite Bar</b>									
CMZ4-HE-XYX-180W-ND -(R)	25,200lm	180W	140lm/W	-40°C	30°C	1-10V	65A	7 @ 230 Vac	5 YRS
CMS4-HP-XYX-180W-DA -(R)	27,000lm	180W	150lm/W	-40°C	30°C	1-10V	65A	7 @ 230 Vac	5 YRS
<b>5 Lite Bar</b>									
CMZ5-HE-XYX-220W-DA -(R)	30,800lm	220W	140lm/W	-40°C	30°C	1-10V	65A	4 @ 230 Vac	5 YRS
CMZ5-HP-XYX-220W-DA -(R)	33,000lm	220W	150lm/W	-40°C	30°C	0-10V	65A	4 @ 230 Vac	5 YRS

- (X)** Correlated Colour Temperature options include: 4000°K **(4)** | 5000°K **(5)** | 6000°K **(6)**
- (YY)** Ra (CRI) Options include Ra85 **(85)**, Ra95. **(95)** Example: 5,000k Ra85, XYX = 585
- (R)** When reflectors\* are required add -R, to end of standard code, blank when not required.
- ND** Non dimming (Vo to reduce output)
- DM** 1-10V Dimming
- DA** DALI

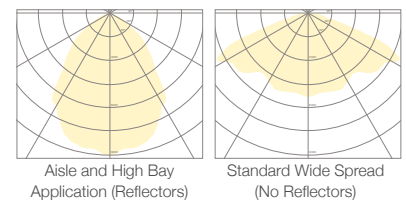

\*High radiant temperatures or unexpected heat sources can potentially damage or significantly impair the performance of the luminaire. Please contact Isollux prior to installation if further information is required.





Intelligent Lighting Solutions

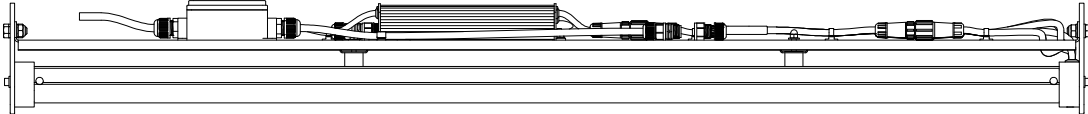
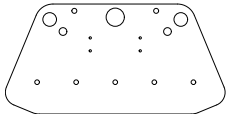
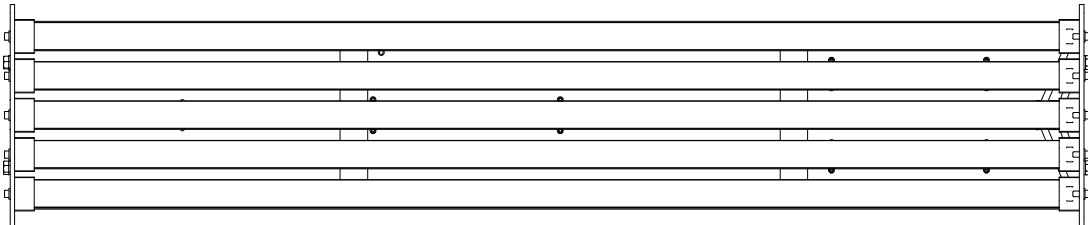
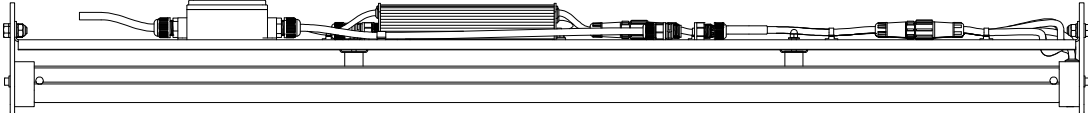
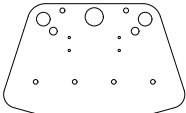
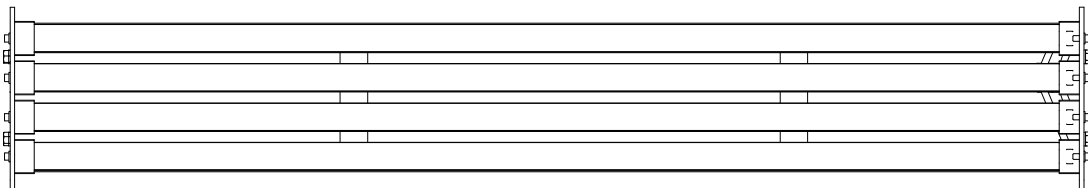

Specifier Series | **ShortBay**

# SB4 Suspension Mount

---

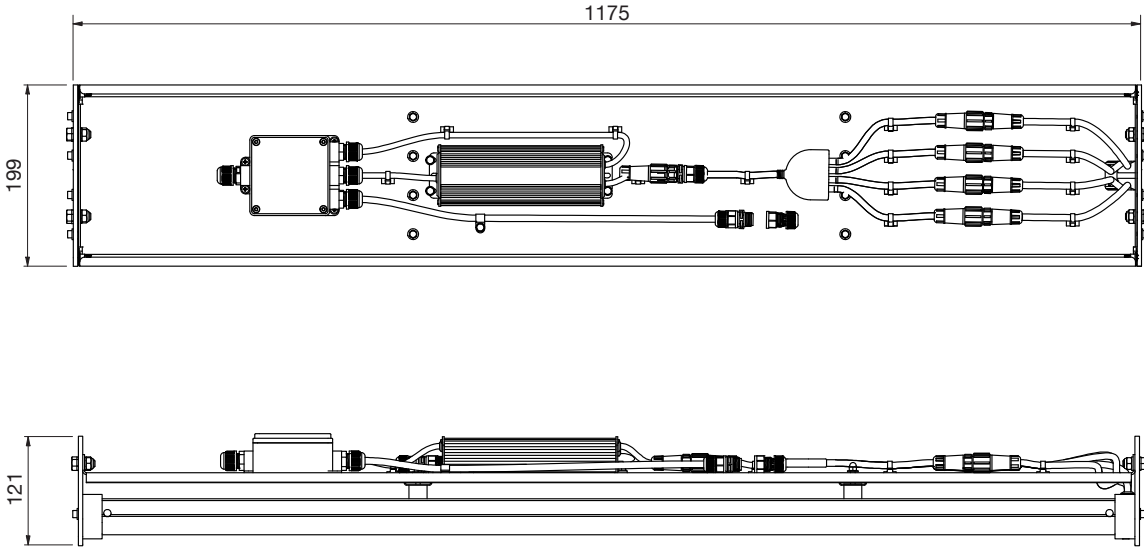

# CMR4 Blast Freezer Mount

---

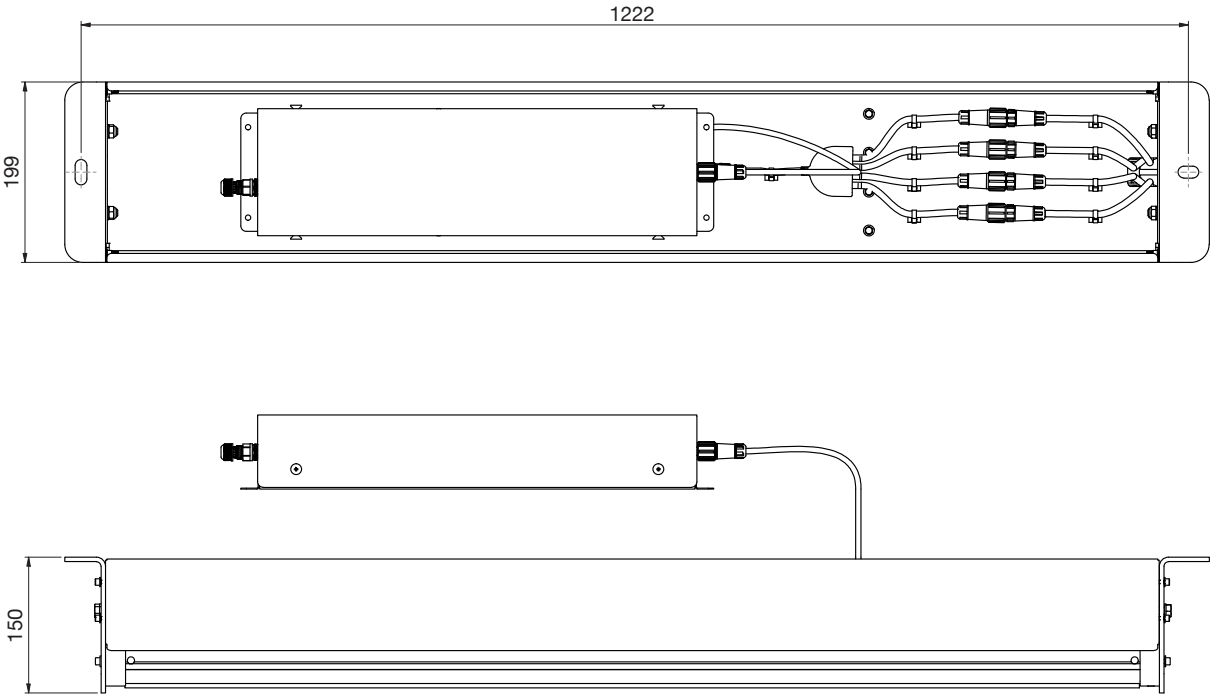

# CMS4 Surface Mount

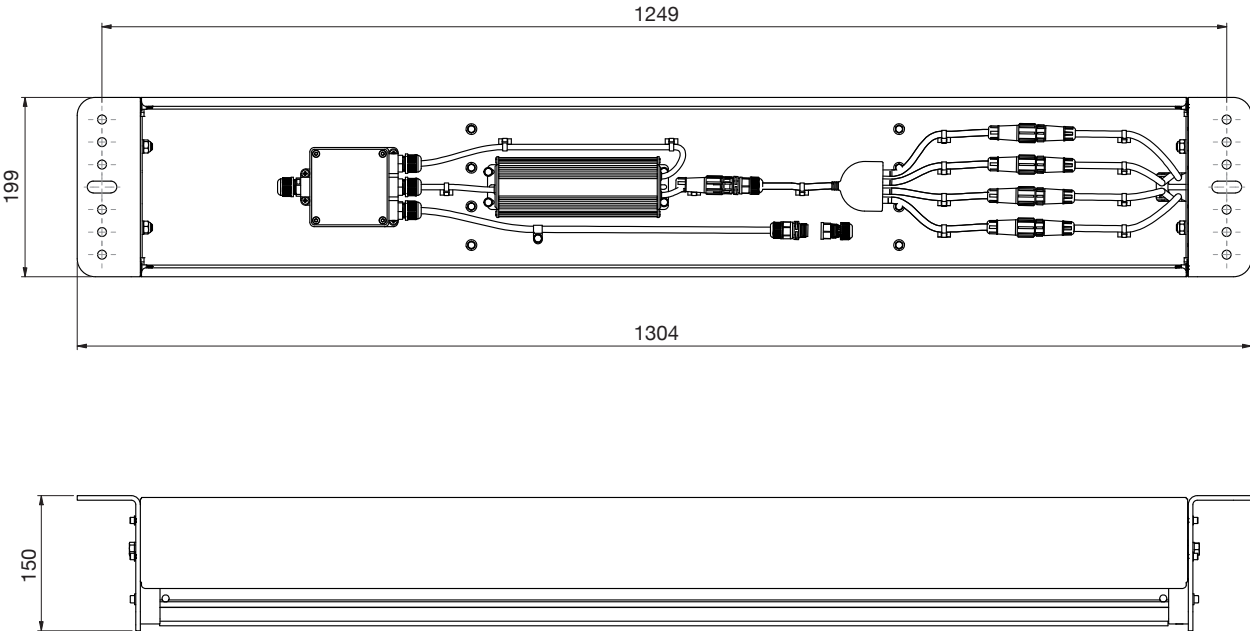

# CMZ4 Surface Mount for ZB Sensor

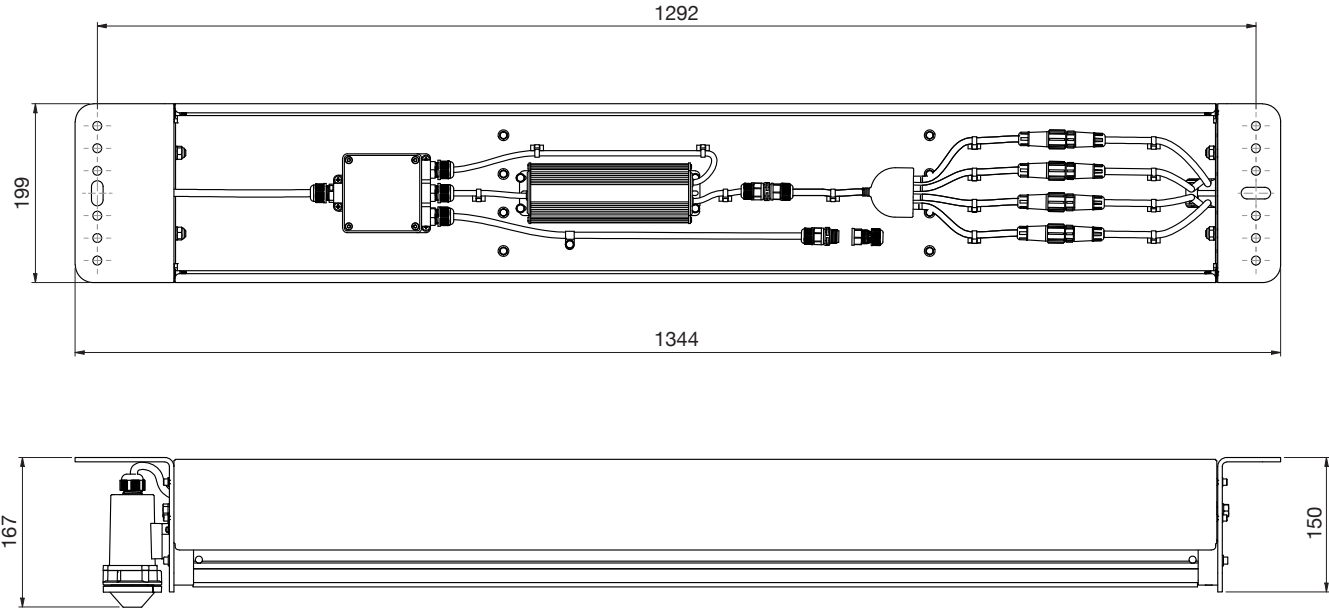

# CM(X)4 End Plates

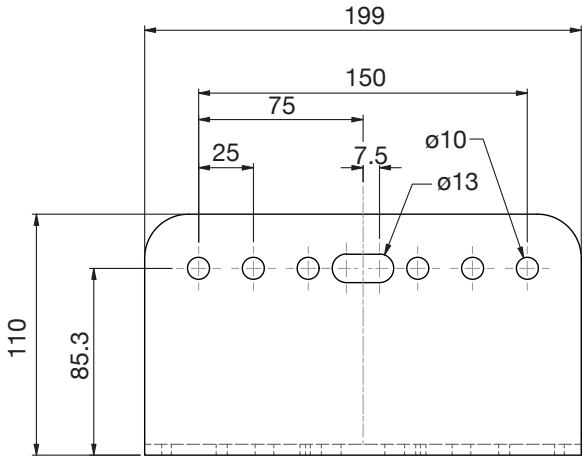

A

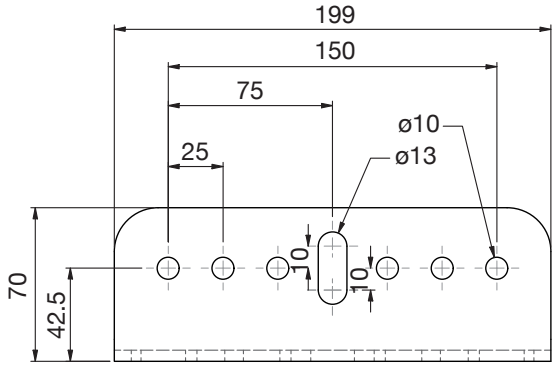

B

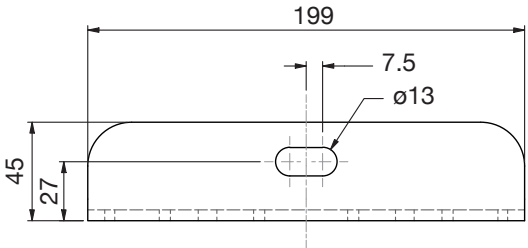

C

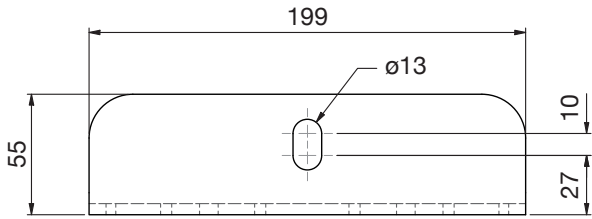

D

MOUNT KIT	DESCRIPTION
CMR4	Plates C + D
CMS4	Plates B + B
CMZ4	Plates A + B

# SB5 Suspension Mount

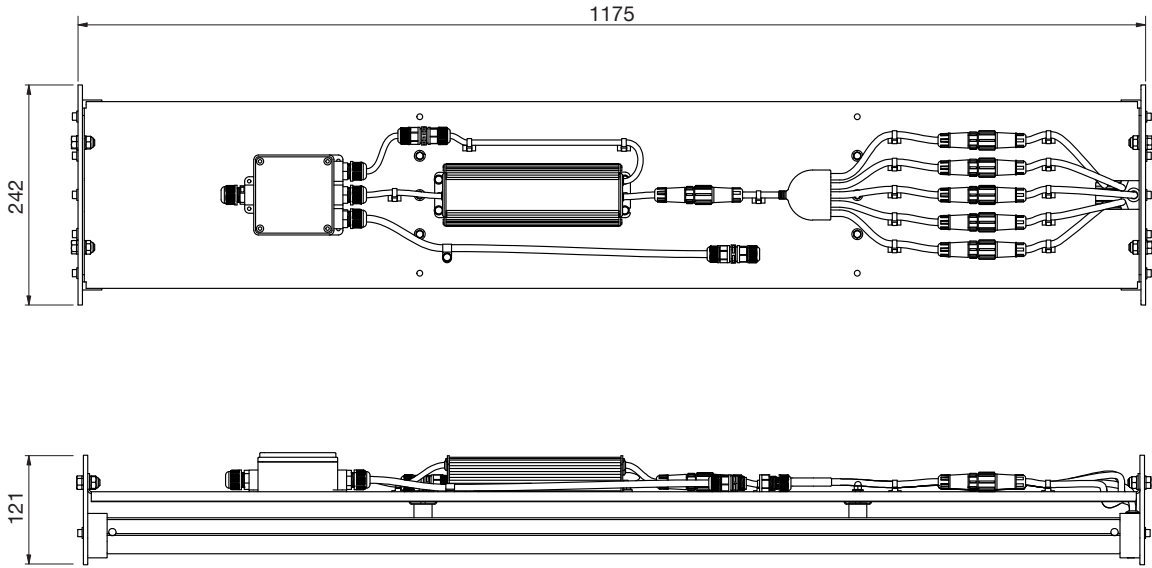

# CMR5 Blast Freezer Mount

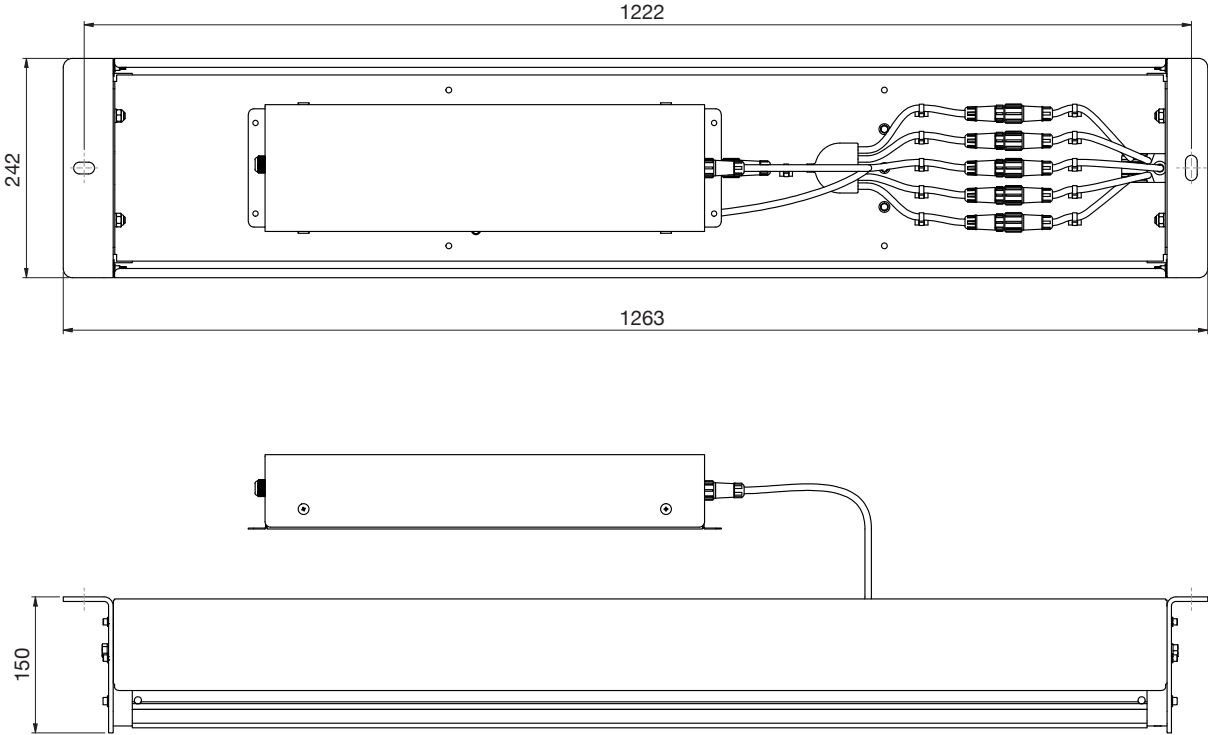

# CMS5 Surface Mount

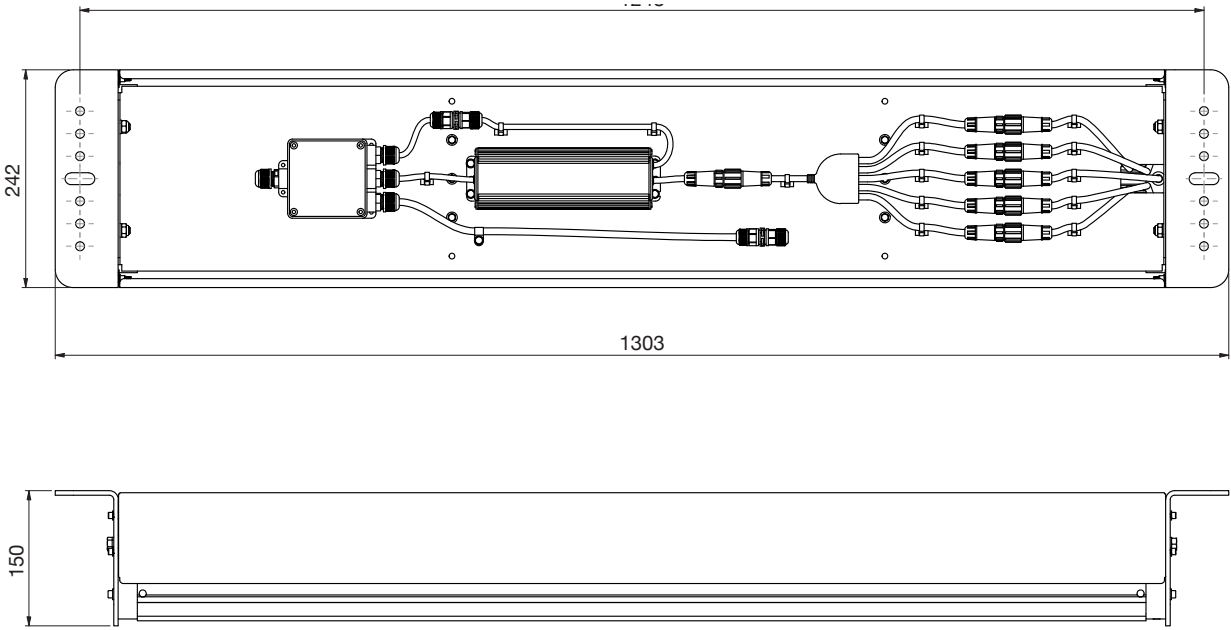

# CMZ5 Surface Mount for ZB Sensor

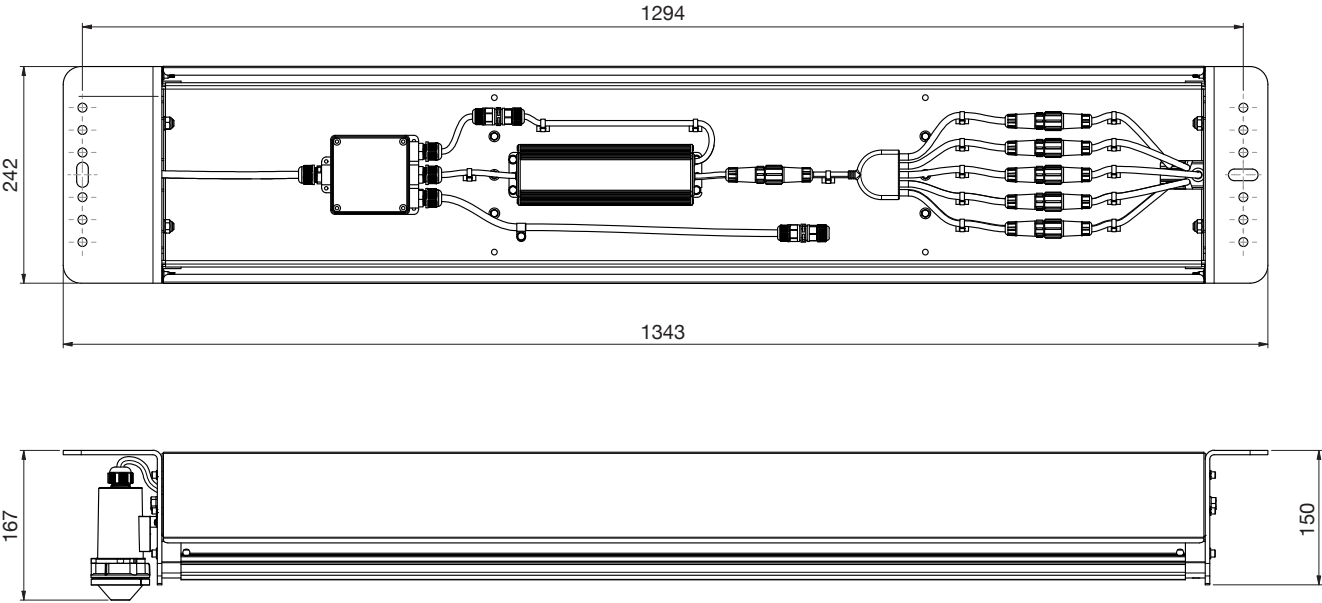

# CM(X)5 End Plates

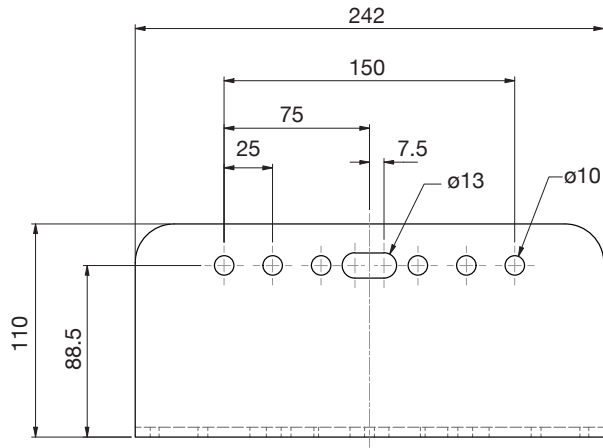

A

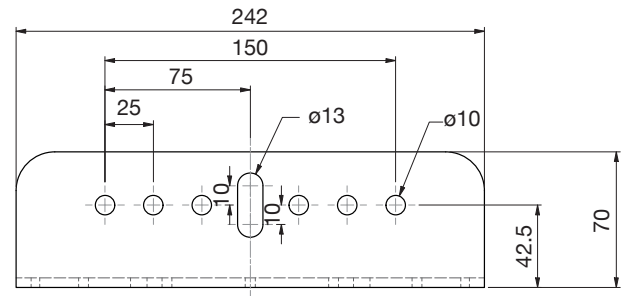

B

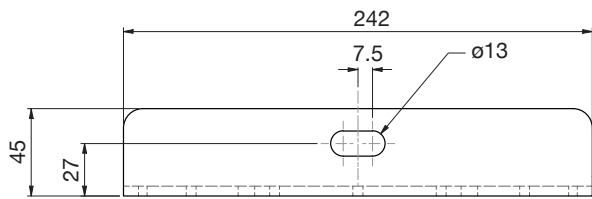

C

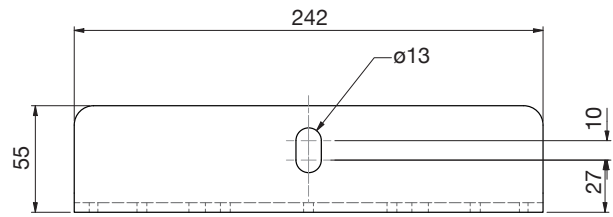

D

MOUNT KIT	DESCRIPTION
CMR5	Plates C + D
CMS5	Plates B + B
CMZ5	Plates A + B



**Contact: Chris Wheatley**

Mobile: + 64 21 343 456

Telephone: + 64 9 446 0822

E.mail: [chris.wheatley@isollux.com](mailto:chris.wheatley@isollux.com)

Regional Authorised Global Partners can be found in the following locations

Sydney – Australia | Fresno – USA | Hong Kong – China | Jaingxi – China